

Somaris

14503852230 Mirror cabinet

PRODUCT



DRAWING

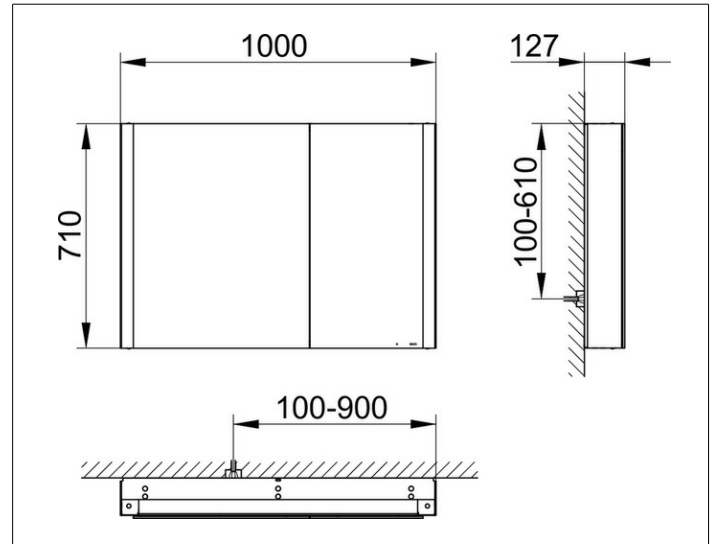

PRODUCT ATTRIBUTES

wall mounted,
 2 hinged double sided crystal mirror doors (asymmetrically),
 Body: aluminium silver anodized
 Rear panel made from HDF
 Operation:
 key panel with capacitive touch sensor,
 integrated extension function for e.g. light switch
 Illumination:
 light colour 3000 kelvin (warm white),
 infinitely dimmable and can be switched on/off
 LED 25 watt (lifespan > 30.000 hours)

EQUIPMENT

- 1 shaver socket
- 3 adjustable glass shelves
- soft-closing door

SURFACE

light oak (decor)

DIMENSION

1000 x 710 x 128 mm