

Edition 400

21533171351 Mirror cabinet

PRODUCT



DRAWING

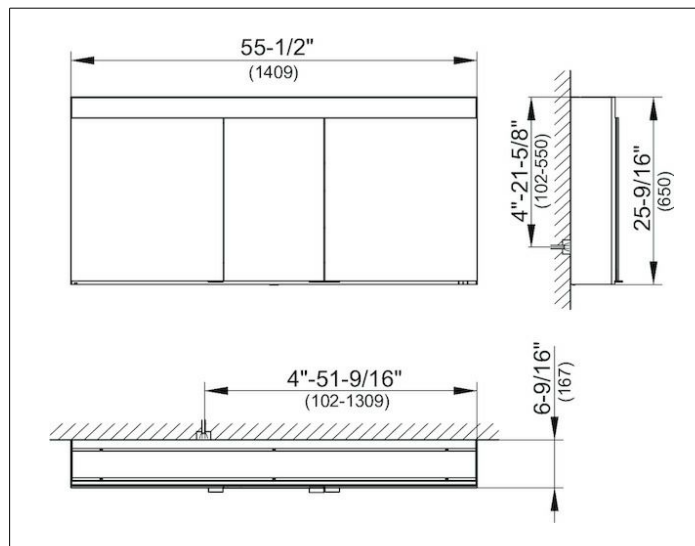

PRODUCT ATTRIBUTES

wall mounted,
 1 light colour, 4000 kelvin (neutral white)
 2 hinged double sided crystal mirrored doors,
 Body: aluminium silver anodized
 Body panels made from rear-lacquered white glass,
 interior rear wall mirrored
 Operation:
 key panel with capacitive touch sensor,
 optional to be operated via the light switch
 Illumination:
 LED 52 watt (lifespan > 30.000 hours)
 infinitely dimmable
 EEK: ,

EQUIPMENT

- 2 sockets
- 2 x 3 adjustable glass shelves
- 2 storage boxes with slidable glass lid
- interior lighting
- soft-closing doors

SURFACE

silver anodized

DIMENSION

1410 x 650 x 167 mm

SPECIFICATIONS

KEUCO Edition 400 Mirror cabinet 21533171351
 High quality Mirror cabinet in elegant design

wall mounted,
 1 light colour, 4000 kelvin (neutral white)
 2 hinged double sided crystal mirrored doors,
 Body: aluminium silver anodized
 Body panels made from rear-lacquered white glass,
 interior rear wall mirrored

Operation:
 key panel with capacitive touch sensor,
 optional to be operated via the light switch

Illumination:
 LED 52 watt (lifespan > 30.000 hours)
 infinitely dimmable

- 2 sockets
- 2 x 3 adjustable glass shelves
- 2 storage boxes with slidable glass lid
- interior lighting
- soft-closing doors

55-9/16" x 25-9/16" x 6-9/16"

silver anodized